

Pull-Down Plates

for Wedge Clamps GN 920.1

SPECIFICATION

- 1 Steel
- 2 Blackened
- 3 Socket cap screw DIN 912 (ISO 4762)
- 4 Steel
- 5 Distance sleeve
- 6 Steel

INFORMATION

Pull-down plates GN 920.2 allow wedge clamps GN 920.1 (see page 1070) to clamp easily with pull-down effect. The socket cap screw and the distance bush are included.

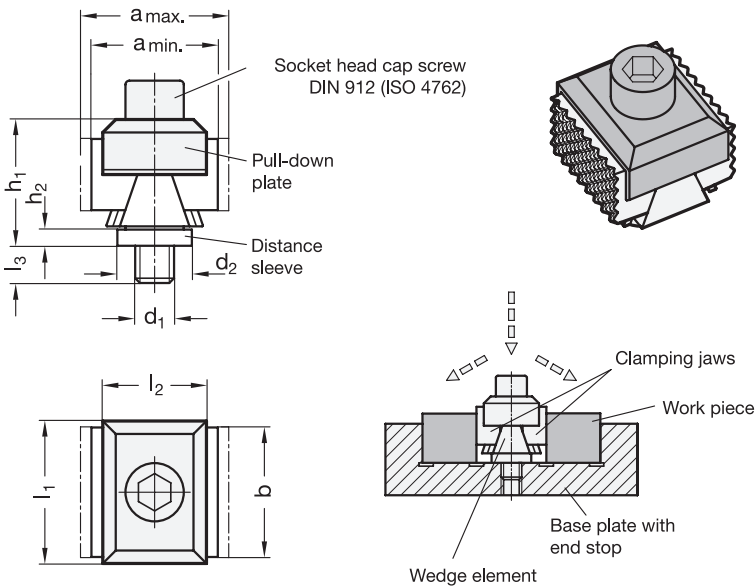

GN 920.2

Description	l1	l2	d1	b	a max.		a min.		d2 Ø	h1 ≈	h2	l3 max.	for wedge clamps GN 920.1		△
					Type GA	Type GL	Type PR	Type RF					with: d	with: b	
GN 920.2-25-32-M8	25	32	M 8	21	44.5	39.5	39.5	34.5	18	27.5	4	7.5	M 8	21	60
GN 920.2-29-32-M8	29	32	M 8	25	44.5	39.5	39.5	34.5	18	27.5	4	7.5	M 8	25	77
GN 920.2-36-32-M8	36	32	M 8	32	44.5	39.5	39.5	34.5	18	27.5	4	7.5	M 8	32	84
GN 920.2-44-32-M8	44	32	M 8	40	44.5	39.5	39.5	34.5	18	27.5	4	7.5	M 8	40	92
GN 920.2-44-32-M12	44	32	M 12	40	45.5	40	45.5	40	23	38	5	11.5	M 12	40	156
GN 920.2-54-32-M8	54	32	M 8	50	44.5	39.5	39.5	34.5	18	27.5	4	7.5	M 8	50	90
GN 920.2-54-32-M12	54	32	M 12	50	45.5	40	45.5	40	23	38	5	11.5	M 12	50	170